



## **Cisco Catalyst Switch Module 3110G, 3110X, and 3012 for IBM BladeCenter Hardware Installation Guide**

April 2008

### **Americas Headquarters**

Cisco Systems, Inc.  
170 West Tasman Drive  
San Jose, CA 95134-1706  
USA  
<http://www.cisco.com>  
Tel: 408 526-4000  
800 553-NETS (6387)  
Fax: 408 527-0883

Text Part Number: OL-12192-01

THE SPECIFICATIONS AND INFORMATION REGARDING THE PRODUCTS IN THIS MANUAL ARE SUBJECT TO CHANGE WITHOUT NOTICE. ALL STATEMENTS, INFORMATION, AND RECOMMENDATIONS IN THIS MANUAL ARE BELIEVED TO BE ACCURATE BUT ARE PRESENTED WITHOUT WARRANTY OF ANY KIND, EXPRESS OR IMPLIED. USERS MUST TAKE FULL RESPONSIBILITY FOR THEIR APPLICATION OF ANY PRODUCTS.

THE SOFTWARE LICENSE AND LIMITED WARRANTY FOR THE ACCOMPANYING PRODUCT ARE SET FORTH IN THE INFORMATION PACKET THAT SHIPPED WITH THE PRODUCT AND ARE INCORPORATED HEREIN BY THIS REFERENCE. IF YOU ARE UNABLE TO LOCATE THE SOFTWARE LICENSE OR LIMITED WARRANTY, CONTACT YOUR CISCO REPRESENTATIVE FOR A COPY.

The following information is for FCC compliance of Class A devices: This equipment has been tested and found to comply with the limits for a Class A digital device, pursuant to part 15 of the FCC rules. These limits are designed to provide reasonable protection against harmful interference when the equipment is operated in a commercial environment. This equipment generates, uses, and can radiate radio-frequency energy and, if not installed and used in accordance with the instruction manual, may cause harmful interference to radio communications. Operation of this equipment in a residential area is likely to cause harmful interference, in which case users will be required to correct the interference at their own expense.

The following information is for FCC compliance of Class B devices: The equipment described in this manual generates and may radiate radio-frequency energy. If it is not installed in accordance with Cisco's installation instructions, it may cause interference with radio and television reception. This equipment has been tested and found to comply with the limits for a Class B digital device in accordance with the specifications in part 15 of the FCC rules. These specifications are designed to provide reasonable protection against such interference in a residential installation. However, there is no guarantee that interference will not occur in a particular installation.

Modifying the equipment without Cisco's written authorization may result in the equipment no longer complying with FCC requirements for Class A or Class B digital devices. In that event, your right to use the equipment may be limited by FCC regulations, and you may be required to correct any interference to radio or television communications at your own expense.

You can determine whether your equipment is causing interference by turning it off. If the interference stops, it was probably caused by the Cisco equipment or one of its peripheral devices. If the equipment causes interference to radio or television reception, try to correct the interference by using one or more of the following measures:

- Turn the television or radio antenna until the interference stops.
- Move the equipment to one side or the other of the television or radio.
- Move the equipment farther away from the television or radio.
- Plug the equipment into an outlet that is on a different circuit from the television or radio. (That is, make certain the equipment and the television or radio are on circuits controlled by different circuit breakers or fuses.)

Modifications to this product not authorized by Cisco Systems, Inc. could void the FCC approval and negate your authority to operate the product.

The Cisco implementation of TCP header compression is an adaptation of a program developed by the University of California, Berkeley (UCB) as part of UCB's public domain version of the UNIX operating system. All rights reserved. Copyright © 1981, Regents of the University of California.

NOTWITHSTANDING ANY OTHER WARRANTY HEREIN, ALL DOCUMENT FILES AND SOFTWARE OF THESE SUPPLIERS ARE PROVIDED "AS IS" WITH ALL FAULTS. CISCO AND THE ABOVE-NAMED SUPPLIERS DISCLAIM ALL WARRANTIES, EXPRESSED OR IMPLIED, INCLUDING, WITHOUT LIMITATION, THOSE OF MERCHANTABILITY, FITNESS FOR A PARTICULAR PURPOSE AND NONINFRINGEMENT OR ARISING FROM A COURSE OF DEALING, USAGE, OR TRADE PRACTICE.

IN NO EVENT SHALL CISCO OR ITS SUPPLIERS BE LIABLE FOR ANY INDIRECT, SPECIAL, CONSEQUENTIAL, OR INCIDENTAL DAMAGES, INCLUDING, WITHOUT LIMITATION, LOST PROFITS OR LOSS OR DAMAGE TO DATA ARISING OUT OF THE USE OR INABILITY TO USE THIS MANUAL, EVEN IF CISCO OR ITS SUPPLIERS HAVE BEEN ADVISED OF THE POSSIBILITY OF SUCH DAMAGES.

Cisco and the Cisco Logo are trademarks of Cisco Systems, Inc. and/or its affiliates in the U.S. and other countries. A listing of Cisco's trademarks can be found at [www.cisco.com/go/trademarks](http://www.cisco.com/go/trademarks). Third party trademarks mentioned are the property of their respective owners. The use of the word partner does not imply a partnership relationship between Cisco and any other company. (1005R)

*Cisco Catalyst Switch Module 3110G, 3110X, and 3012 for IBM BladeCenter Hardware Installation Guide*  
©2008 Cisco Systems, Inc. All rights reserved.



# CONTENTS

## **Preface** vii

Audience vii

Purpose vii

Conventions vii

Related Publications viii

Obtaining Documentation, Obtaining Support, and Security Guidelines viii

---

## **CHAPTER 1**

### **Product Overview** 1-1

Switch Modules 1-1

Hardware Features 1-2

10/100/1000 Ethernet Ports 1-3

10-Gigabit Ethernet Module Slot 1-4

Port Numbering 1-4

Internal 100BASE-T Ethernet Management Port 1-4

Switch Module LEDs 1-5

StackWise Plus Ports 1-9

Console Port 1-9

Management Options 1-9

Network Configurations 1-10

---

## **CHAPTER 2**

### **Switch Module Installation** 2-1

Preparing for Installation 2-1

Safety Warnings 2-1

Installation Guidelines 2-3

Box Contents 2-3

Installing the Switch Module 2-4

After Installing the Switch Module 2-5

Creating Switch Stacks 2-6

Stacking Guidelines 2-6

Connecting a Switch Stack 2-7

Switch Stack Cabling Examples 2-8

Installing Devices in the 10-Gigabit Ethernet Slot 2-11

Installing an X2 Transceiver Module 2-11

Connecting Devices to the Ethernet Ports 2-13

Where to Go Next 2-13

---

**CHAPTER 3**

**Troubleshooting 3-1**

Diagnosing Problems 3-1

Verify Switch Module POST Results 3-1

Verify Switch Module LEDs 3-1

Verify Switch Module Connections 3-2

Verify Switch Module Performance 3-4

Resetting the Switch Module 3-4

Using the Mode Button to Reset the Switch Module 3-5

How to Replace a Failed Stack Member 3-5

---

**APPENDIX A**

**Technical Specifications A-1**

---

**APPENDIX B**

**Connector and Cable Specifications B-1**

Connector Specifications B-1

10/100/1000 Ports B-1

10-Gigabit Ethernet Module Interface B-2

Console Port B-2

Cable and Adapter Specifications B-2

10-Gigabit Ethernet X2 Transceiver Module Cable Specifications B-3

Four Twisted-Pair Cable Pinouts B-4

Two Twisted-Pair Cable Pinouts B-5

Identifying a Crossover Cable B-5

---

**INDEX**



## Preface

---

### Audience

This guide is for the networking or computer technician responsible for installing a Cisco Catalyst switch module. We assume that you are familiar with the concepts and terminology of Ethernet and local area networking.

### Purpose

This guide documents the hardware features of the Cisco Catalyst Switch Module 3110G, 3110X, and 3012 for IBM BladeCenter—referred to as the *switch module*. It describes the physical and performance characteristics of each switch module, explains how to install a switch module, and provides troubleshooting information.

This guide does not describe system messages that you might receive or how to configure your switch module. For more information, see the switch module getting started guide, the software configuration guide, the command reference, and the system message guide on Cisco.com. For information about the standard Cisco IOS Release 12.1 or 12.2 commands, see the Cisco IOS documentation set from the Cisco.com home page at **Technical Support and Documentation > Documentation**. On the Cisco Documentation home page, select Release **12.1** or **12.2** from the Cisco IOS Software drop-down list.

### Conventions

This document uses the following conventions and symbols for notes, cautions, and warnings. Translations of the warning statements in this document appear in the *Regulatory Compliance and Safety Information for the Cisco Catalyst Switch Module 3110G, 3110X, and 3012 for IBM BladeCenter* that ships with the switch.



---

**Note**

Means *reader take note*. Notes contain helpful suggestions or references to materials not contained in this manual.

---



---

**Caution**

Means *reader be careful*. In this situation, you might do something that could result in equipment damage or loss of data.

---

**Warning**

**This warning symbol means danger. You are in a situation that could cause bodily injury. Before you work on any equipment, be aware of the hazards involved with electrical circuitry and be familiar with standard practices for preventing accidents. Use the statement number provided at the end of each warning to locate its translation in the translated safety warnings that accompanied this device.**  
Statement 1071

## Related Publications

For more information about the switch module, see these documents on Cisco.com:

[http://www.cisco.com/en/US/products/ps8741/tsd\\_products\\_support\\_series\\_home.html](http://www.cisco.com/en/US/products/ps8741/tsd_products_support_series_home.html)

- *Cisco Catalyst Switch Module 3110G, 3110X, and 3012 for IBM BladeCenter Software Configuration Guide.* This guide provides a product overview and detailed descriptions and procedures for the switch module software features.
- *Cisco Catalyst Switch Module 3110G, 3110X, and 3012 for IBM BladeCenter Command Reference.* This reference provides detailed descriptions of the Cisco IOS commands specifically created or modified for the switch module.
- *Cisco Catalyst Switch Module 3110G, 3110X, and 3012 for IBM BladeCenter System Message Guide.* This guide provides descriptions of the system messages specifically created or modified for the switch module.
- *Cisco Software Activation Document for IBM BladeCenter.* This document describes the supported feature sets, software licenses, and information about using software activation in mixed software switch stacks.
- *Cisco Catalyst Switch Module 3110G, 3110X, and 3012 for IBM BladeCenter Getting Started Guide.* This guide provides instructions on how to install and manage the switch module.
- *Regulatory Compliance and Safety Information for the Cisco Catalyst Switch Module 3110G, 3110X, and 3012 for IBM BladeCenter.* This guide contains agency approvals, compliance information, and translated warning statements.
- *Release Notes for the Cisco Catalyst Switch Module 3110G, 3110X, and 3012 for IBM BladeCenter.* The release notes include the system requirements, important notes, limitations, open and resolved caveats, and documentation updates.

For more information about the IBM BladeCenter enclosure, see the IBM documentation at:

<http://www-03.ibm.com/systems/bladecenter/>

## Obtaining Documentation, Obtaining Support, and Security Guidelines

For information on obtaining documentation, obtaining support, providing documentation feedback, security guidelines, and also recommended aliases and general Cisco documents, see the monthly *What's New in Cisco Product Documentation*, which also lists all new and revised Cisco technical documentation, at:

<http://www.cisco.com/en/US/docs/general/whatsnew/whatsnew.html>



# CHAPTER 1

## Product Overview

The Cisco Catalyst Switch Module 3110G, 3110X, and 3012 for IBM BladeCenter—referred to as the *switch modules*—are Ethernet switch modules that you install in an IBM BladeCenter enclosure—referred to as the *blade enclosure*. You can connect devices to the switch modules for connections to other network devices such as routers, servers, and other switches.

The Catalyst Switch Module 3110G and 3110X support stacking through Cisco StackWise Plus technology. The Catalyst Switch Module 3012 does not support stacking. Unless otherwise noted, the term *switch module* refers to a standalone switch module and to a switch stack.



### Note

This product is not intended to be connected directly or indirectly by any means whatsoever to interfaces of public telecommunications networks.

This chapter provides a functional overview of the switch modules and covers these topics:

- [Switch Modules, page 1-1](#)
- [Hardware Features, page 1-2](#)
- [Management Options, page 1-9](#)

## Switch Modules

[Table 1-1](#) describes the switch modules.

**Table 1-1** Catalyst Switch Module 3110G, 3110X, and 3012

Switch Model	Cisco Part Number	IBM Part Number	Description
Catalyst Switch Module 3110G	WS-CBS3110G-S	WS-CBS3110G-S-I	4 external 10/100/1000BASE-T Ethernet ports, 14 internal 1000BASE-X Ethernet downlink ports, 1 internal 100BASE-T Ethernet management port, 2 StackWise Plus ports

**Table 1-1 Catalyst Switch Module 3110G, 3110X, and 3012 (continued)**

Switch Model	Cisco Part Number	IBM Part Number	Description
Catalyst Switch Module 3110X	WS-CBS3110X-S	WS-CBS3110X-S-I	1 external 10-Gigabit Ethernet module slot, 14 internal 1000BASE-X Ethernet downlink ports, 1 internal 100BASE-T Ethernet management port, 2 StackWise Plus ports
Catalyst Switch Module 3012	WS-CBS3012-IBM	WS-CBS3012-IBM-I	4 external 10/100/1000BASE-T Ethernet ports, 14 internal 1000BASE-X Ethernet downlink ports, 1 internal 100BASE-T Ethernet management port

## Hardware Features

The Catalyst Switch Module 3110G and 3110X include the 10/100/1000 Ethernet ports or the 10-Gigabit Ethernet module slot, console port, StackWise Plus ports, release latch, and the switch module LEDs shown in [Figure 1-1](#) and described on the following pages.

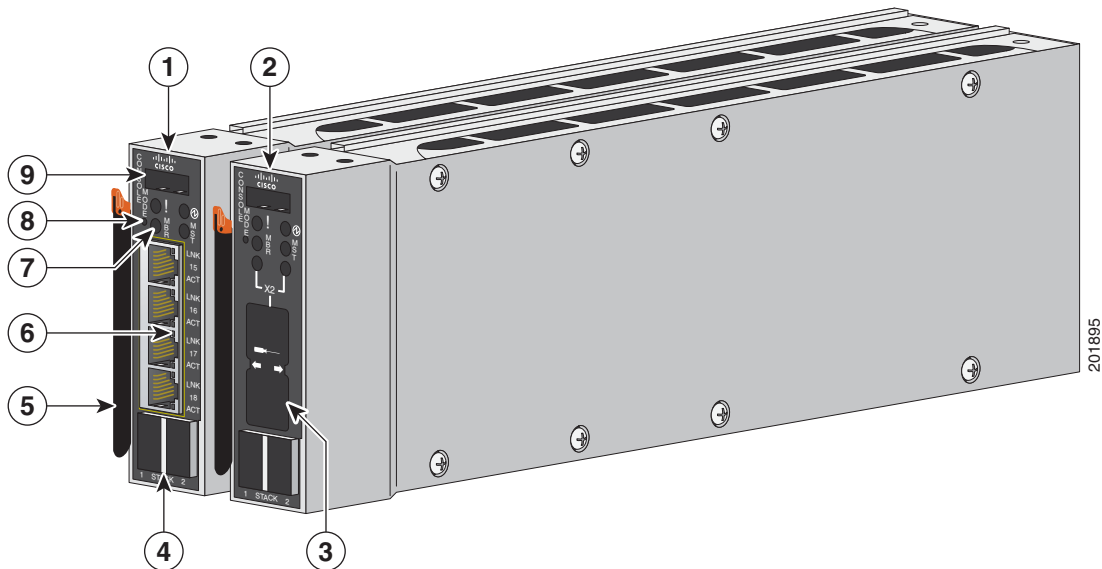
**Figure 1-1 Catalyst Switch Module 3110G and 3110X**

1	Catalyst Switch Module 3110G	6	10/100/1000 Ethernet ports
2	Catalyst Switch Module 3110X	7	Switch module LEDs
3	10-Gigabit Ethernet module slot <sup>1</sup>	8	Mode button
4	StackWise Plus ports	9	Console port
5	Release latch		

1. For use with Cisco X2 transceiver modules.



The Catalyst Switch Module 3012 includes the 10/100/1000 Ethernet ports, console port, release latch, and the switch module LEDs shown in [Figure 1-2](#) and described on the following pages.

**Figure 1-2 Catalyst Switch Module 3012**

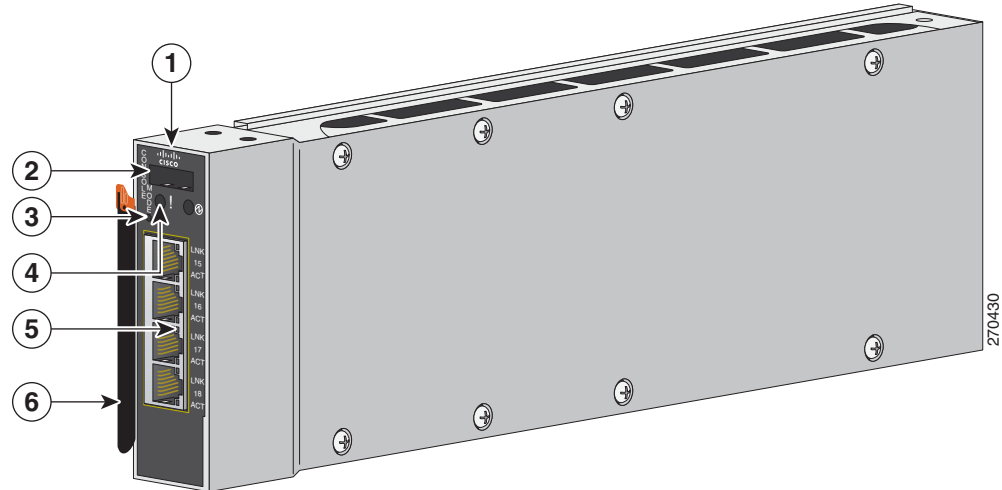

1	Catalyst Switch Module 3012	4	Switch module LEDs
2	Console port	5	10/100/1000 Ethernet ports
3	Mode button	6	Release latch

## 10/100/1000 Ethernet Ports

The Catalyst Switch Module 3110G and 3012 10/100/1000 Ethernet ports use standard RJ-45 connectors with Ethernet pinouts. The maximum cable length is 328 feet (100 meters). The 100BASE-TX and 1000BASE-T traffic requires Category 5, Category 5e, or Category 6 unshielded twisted pair (UTP) cable. The 10BASE-T traffic can use Category 3 or Category 4 UTP cable.

For information about the 10/100/1000 Ethernet port connections and specifications, see the [“Connecting Devices to the Ethernet Ports”](#) section on page 2-13 and [Appendix B, “Connector and Cable Specifications.”](#)

## 10-Gigabit Ethernet Module Slot

The Catalyst Switch Module 3110X 10-Gigabit Ethernet module slot is used for an uplink connection to other switches and routers. The module slot operates in full-duplex mode and uses the hot-swappable Cisco X2 transceiver modules.

The X2 transceiver modules have a dual SC/PC connector (-SR, -LX4) or an Infiniband 4x connector (-CX4) for connections to multimode fiber (MMF), single-mode fiber (SMF), or 4x Infiniband cable.

These are the supported Cisco X2 transceiver modules:

- X2-10GB-SR
- X2-10GB-CX4
- X2-10GB-LX4

For information about installing a transceiver module, see the [“Installing Devices in the 10-Gigabit Ethernet Slot” section on page 2-11](#). For cable specifications, see [Appendix B, “Connector and Cable Specifications.”](#)

## Port Numbering

[Table 1-2](#) describes the switch module port numbering.

**Table 1-2**      **Switch Module Port Numbering**

Port	Description
Ports 1 to 14 <sup>1</sup>	Internal Gigabit Ethernet 1000BASE-X downlink ports that connect to the blade enclosure.
Ports 15 to 18 (Catalyst Switch Module 3110G and 3012)	External 10/100/1000BASE-T copper Gigabit Ethernet uplink ports.
Port 1 (X2) (Catalyst Switch Module 3110X)	External 10-Gigabit Ethernet module slot.

1. The number of internal ports is determined by the blade enclosure model. See the blade enclosure documentation for more information about internal port numbering.

## Internal 100BASE-T Ethernet Management Port

The internal Ethernet management port (Fa0) is used only for switch module management traffic, not for data traffic. It is connected to the IBM advanced Management Module (aMM) through the blade enclosure backplane connector. Traffic to and from this port is isolated from the switch module ports. This port only supports autonegotiation with 100 Mb/s and full-duplex mode.

# Switch Module LEDs

You can use the switch module LEDs to monitor switch module activity. [Figure 1-3](#) shows the switch module LEDs and the Mode button that you use to activate the different modes.

**Figure 1-3** Switch Module LEDs and Mode Button

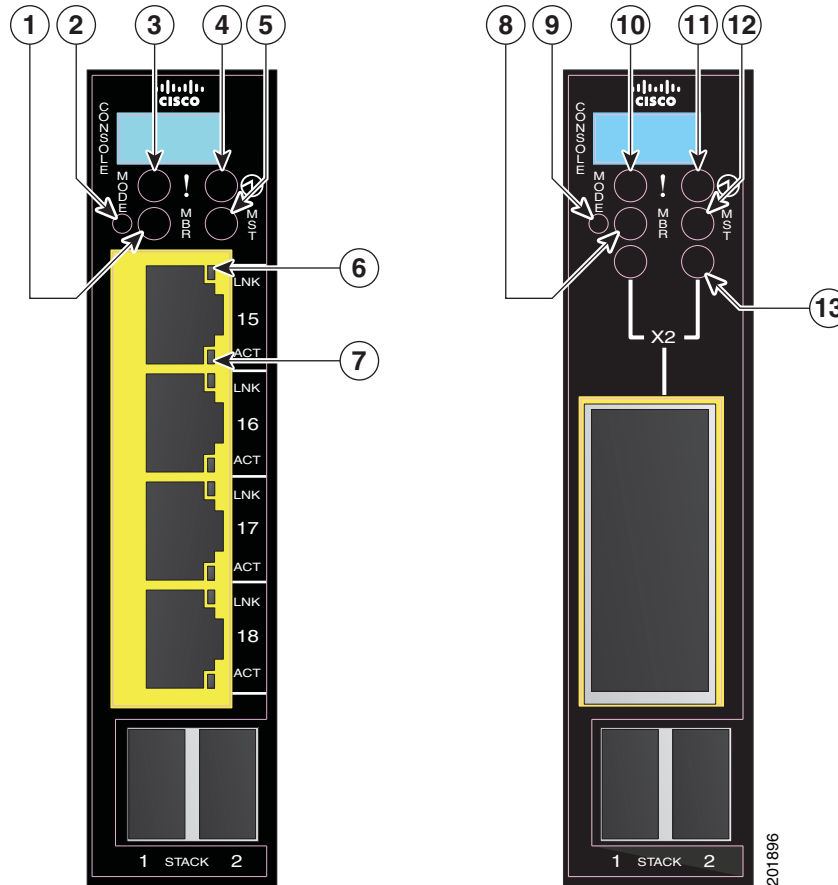

<b>1</b>	Stack member LED (Catalyst Switch Module 3110G)	<b>8</b>	Stack member LED
<b>2</b>	Mode button	<b>9</b>	Mode button
<b>3</b>	Fault/stack mode LED (Catalyst Switch Module 3110G) Fault LED (Catalyst Switch Module 3012)	<b>10</b>	Fault/stack mode LED
<b>4</b>	System power LED	<b>11</b>	System power LED
<b>5</b>	Stack master LED (Catalyst Switch Module 3110G)	<b>12</b>	Stack master LED
<b>6</b>	Port link LED	<b>13</b>	X2 port status LEDs
<b>7</b>	Port activity LED		

## Mode Button

The fault/stack or stack member LEDs are selected by using the Mode button. If the mode LED for a particular mode is solid green, that mode is currently selected, and the other mode LEDs are off (only Catalyst Switch Module 3110G and 3110X).

To select or change a mode, use a small pointed object to press the Mode button until the desired mode is selected.

## System Power LED

The system power LED shows whether the system is receiving power and is functioning properly. [Table 1-3](#) lists the LED colors and their meanings.

**Table 1-3 System LED**

Color	System Status
Off	Switch module is not powered on.
Green	Switch module is operating normally.
Amber	Switch module is receiving power but is not functioning properly.
Blinking green	Switch module is running the power-on self-test (POST).

## Stack Master LED

The stack master LED shows the stack master status. [Table 1-4](#) lists the LED colors and their meanings (only Catalyst Switch Module 3110G and 3110X).

**Table 1-4 Stack Master LED**

Color	Description
Off	Switch module is not the stack master.
Green	Switch module is the stack master or a standalone switch.
Amber	An error occurred during stack master election, or another type of stack error occurred.

## Fault/Stack Mode LED

The fault/stack mode LED shows either a fault condition or the switch stack status, depending on the Mode button selection. When the switch module is not stacked and there is no fault, the LED is off. If the switch module is stacked and the stack mode LED is selected, the stack member LED is active. [Table 1-5](#) lists the LED colors and their meanings (only Catalyst Switch Module 3110G and 3110X).

**Table 1-5** *Fault/Stack Mode LED*

Color	Fault Mode Description	Stack Mode Description
Off	No switch module faults.	Stack mode is not selected.
Green	—	Switch stack mode is selected. When this LED is green, the stack member LED displays the stack membership number, and the port LEDs display link status.
Amber	Switch module fault detected.	—

## Fault LED

The fault LED shows the switch module fault condition. [Table 1-6](#) lists the LED colors and their meanings (only Catalyst Switch Module 3012).

**Table 1-6** *Fault LED*

Color	Fault Mode Description
Off	No switch module faults.
Amber	Switch module fault detected.

## Stack Member LED

The stack member LED is active when the switch module is stacked and you select by using the Mode button. The stack member LED blinks the number of times equal to the switch stack membership number. [Table 1-7](#) lists the LED colors and their meanings (only Catalyst Switch Module 3110G and 3110X).

**Table 1-7** *Fault/Stack Mode LED*

Color	Description
Off	Stack mode is not selected, or the switch module is not stacked.
Blinking green	Stack member number.

## Port LEDs

The Catalyst Switch Module 3110G and 3012 port LEDs show interface activity and link status. [Table 1-8](#) lists the LED colors and their meanings.

**Table 1-8 Catalyst Switch Module 3110G and 3012 Port LEDs**

Color	Activity LED Description	Link Status LED Description
Off	No activity.	No link, or port was administratively shut down.
Green	—	Link present, or the port might be blocked by Spanning Tree Protocol (STP) and is not forwarding data.
Blinking green	Activity. Port is sending or receiving data.	—

When stack mode is selected on a Catalyst Switch Module 3110G, port 4 activity and link LEDs show the status for StackWise Plus ports 1 and 2, respectively. The other port LEDs are off. [Table 1-9](#) lists the LED colors and their meanings.

**Table 1-9 Catalyst Switch Module 3110G Port LEDs with Stack Mode Selected**

Color	Activity LED Description	Link Status LED Description
Off	No link.	No link.
Green	Switch stack link is active.	Switch stack link is active.

The Catalyst Switch Module 3110X port status LEDs show interface activity and link status. (The LEDs combine to display status when an X2 transceiver is inserted.) [Table 1-10](#) lists the LED colors and their meanings.

**Table 1-10 Catalyst Switch Module 3110X Port LEDs**

Color	LED Description
Off	No link, or port was administratively shut down.
Green	Link present.
Blinking green	Activity. Port is sending or receiving data.
Amber	Port is blocked by STP and is not forwarding data, or port was administratively shut down.
Alternating green-amber	Link fault.

When stack mode is selected on a Catalyst Switch Module 3110X, the two port status LEDs show the status for StackWise Plus ports 1 and 2, respectively. [Table 1-11](#) lists the LED colors and their meanings.

**Table 1-11 Catalyst Switch Module 3110X Port Status LEDs with Stack Mode Selected**

Color	Port Status LED Description
Off	No link.
Green	Switch stack link is active.

## StackWise Plus Ports

The switch module ships with a 1-meter StackWise Plus cable that you can use to connect the StackWise Plus ports (only Catalyst Switch Module 3110G and 3110X).



### Caution

Use only approved cables and connect only to Catalyst Switch Module 3110G and 3110X. Equipment might be damaged if connected to nonapproved Cisco cables or equipment.

You can order these StackWise Plus cables from your supplier:

- CAB-STK-E-0.5M= (0.5-meter cable)
- CAB-STK-E-1M= (1-meter cable)
- CAB-STK-E-3M= (3-meter cable)

## Console Port

You can connect the switch module to a host such as a PC, workstation, or a terminal server through the console port (shown in [Figure 1-1](#)). Use the supplied USB-to-DB-9 cable to connect the switch module to a host.

For more information about the console port, see the switch module getting started guide, the software configuration guide, and the command reference on [Cisco.com](#).

## Management Options

The switch module offers several management options:

- Cisco IOS CLI

The switch module command-line interface (CLI) is based on Cisco IOS software and is enhanced to support desktop-switching features. You can fully configure and monitor the switch module and switch stack members from the CLI. You can access the CLI by connecting your management station directly to the switch module console port or by using Telnet from a remote management station. See the switch module getting started guide, the software configuration guide, and the command reference on [Cisco.com](#) for more information.

- BladeCenter Advanced Management Module

For standalone switch modules, you can use the aMM to configure the switch module. See the *IBM BladeCenter Advanced Management Module User's Guide* for more information. For stacked switches, use the CLI to configure and manage the switch stack.

- IBM Director

For standalone switch modules, you can use the IBM Director to view the hardware configuration of remote systems, monitor the usage and performance of critical components, centrally manage individual or large groups of IBM and non-IBM Intel®-processor-based servers, desktop computers, workstations, and mobile computers on a variety of platforms. See the IBM documentation for more information.

- Device manager

You can use the device manager, which is in the switch module memory, to manage standalone switch modules and switch stacks. This web interface offers quick configuration and monitoring. You can access the device manager from anywhere in your network through a web browser. For more information, see the getting started guide and the device manager online help.

- Cisco Network Assistant

Cisco Network Assistant is a PC-based network management GUI application optimized for LANs of small and medium-sized businesses. Cisco Network Assistant offers centralized management of Cisco switches ranging from the Catalyst Express 500 through the Cisco Catalyst 4506. Through a GUI, users can configure and manage standalone switch modules and switch stacks. Cisco Network Assistant is available at no cost and can be downloaded from this URL:

[http://www.cisco.com/go/cna\\_doc](http://www.cisco.com/go/cna_doc)

For information on starting the Network Assistant application, see the *Getting Started with Cisco Network Assistant* guide on Cisco.com.

- SNMP network management

You can manage switch modules from a SNMP-compatible management station. The switch module supports a comprehensive set of Management Information Base (MIB) extensions and four Remote Monitoring (RMON) groups. See the switch module software configuration guide on Cisco.com and the documentation that came with your SNMP application for more information.

- CiscoWorks application

The CiscoWorks device-management application displays the switch module image that you can use to set configuration parameters and to view switch module status and performance information. The CiscoView application, which you purchase separately, can be a standalone application or part of a Simple Network Management Protocol (SNMP) platform. See the CiscoView documentation for more information.

## Network Configurations

See the switch module software configuration guide on Cisco.com for network configuration concepts and examples of using the switch module to create dedicated network segments and interconnecting the segments through Gigabit Ethernet connections.





## CHAPTER 2

# Switch Module Installation

---

This chapter describes how to install the Catalyst Switch Module 3110G, 3110X, and 3012 and make connections to the switch module. It also includes planning and cabling considerations for stacking switch modules. Read the topics and perform the procedures in this order:

- [Preparing for Installation, page 2-1](#)
- [Installing the Switch Module, page 2-4](#)
- [Creating Switch Stacks, page 2-6](#)
- [Installing Devices in the 10-Gigabit Ethernet Slot, page 2-11](#)
- [Connecting Devices to the Ethernet Ports, page 2-13](#)
- [Where to Go Next, page 2-13](#)

## Preparing for Installation

This section covers these topics:

- [Safety Warnings, page 2-1](#)
- [Installation Guidelines, page 2-3](#)
- [Box Contents, page 2-3](#)

## Safety Warnings

This section includes the basic installation caution and warning statements. Translations of the warning statements appear in the *Regulatory Compliance and Safety Information for the Cisco Catalyst Switch Module 3110G, 3110X, and 3012 for IBM BladeCenter* that shipped with the switch module and online at Cisco.com. Read this section before you start the installation procedure.

The switch module is for use only in Listed IBM BladeCenter products. See the switch module release notes on Cisco.com for Listed IBM BladeCenter products.



**Warning**

---

**Before working on equipment that is connected to power lines, remove jewelry (including rings, necklaces, and watches). Metal objects will heat up when connected to power and ground and can cause serious burns or weld the metal object to the terminals.** Statement 43

---

**Warning****Ethernet cables must be shielded when used in a central office environment.** Statement 171**Warning****Do not reach into a vacant slot or chassis while you install or remove a module or a fan. Exposed circuitry could constitute an energy hazard.** Statement 206**Warning****Do not work on the system or connect or disconnect cables during periods of lightning activity.** Statement 1001**Warning****Read the installation instructions before connecting the system to the power source.** Statement 1004**Warning****Class 1 laser product.** Statement 1008**Warning****This unit is intended for installation in restricted access areas. A restricted access area can be accessed only through the use of a special tool, lock and key, or other means of security.** Statement 1017**Warning****Ultimate disposal of this product should be handled according to all national laws and regulations.** Statement 1040**Warning****For connections outside the building where the equipment is installed, the following ports must be connected through an approved network termination unit with integral circuit protection: 10/100/1000 Ethernet.** Statement 1044**Warning****To prevent the system from overheating, do not operate it in an area that exceeds the maximum recommended ambient temperature of: 131° F (55° C).** Statement 1047**Warning****Installation of the equipment must comply with local and national electrical codes.** Statement 1074

## Installation Guidelines

**Note**

This product is not intended to be connected directly or indirectly by any means whatsoever to interfaces of public telecommunications networks.

Consider these guidelines before you install the switch module:

- Fill any unoccupied interconnect bays or any unoccupied power module bays in the blade enclosure with filler modules.
- Identify the bays in which you will insert the switch modules. Plan to install the first switch module in bay 1, the second in bay 2, and so on up to bay 4, if possible.  
See the IBM blade enclosure documentation for more information about the specific enclosure model, the interconnect bay options, and the port mapping between the blade enclosure and the switch modules.
- For switch stacks, you should first install and configure the switch module that will be the stack master before installing any additional switch modules. See the [“Creating Switch Stacks” section on page 2-6](#) for more information.
- The orange release latch on the switch module means that it is hot-swappable. To maintain proper system cooling, you must replace a hot-swap switch module within 1 minute of removal.
- Verify that clearance to the switch-module front panel is such that
  - Front-panel indicators can be easily read.
  - Access to ports is sufficient for unrestricted cabling.
  - The X2-10GB-CX4 transceiver-module minimum-bend radius and connector length is met. See the X2 transceiver module documentation for more information.
- Confirm that cabling is away from sources of electrical noise, such as radios, power lines, and fluorescent lighting fixtures. Make sure that the cabling is safely away from other devices that might damage the cables.
- For copper connections on Ethernet ports, cable lengths from the switch module to connected devices can be up to 328 feet (100 meters).
- For cable requirements for X2 module connections, see the [“Cable and Adapter Specifications” section on page B-2](#). Each port must match the wave-length specifications on the other end of the cable, and the cable must not exceed the required cable length.
- Operating environment is within the ranges listed in [Appendix A, “Technical Specifications.”](#)
- Review and become familiar with the safety guidelines in the *Regulatory Compliance and Safety Information for the Cisco Catalyst Switch Module 3110G, 3110X, and 3012 for IBM BladeCenter* on the documentation CD.
- Review and become familiar with the safety guidelines, and the temperature, power, and grounding requirements specified in the IBM blade enclosure installation and user’s guide.

## Box Contents

The box contents are described in the switch module getting started guide. If any item is missing or damaged, contact your supplier for support.

# Installing the Switch Module

This section covers switch module installation. The illustrations in this section show the Catalyst Switch Module 3110G. The instructions are the same for the Catalyst Switch Module 3110X and 3012.

Follow these steps:

- Step 1** Remove the acoustic attenuation module, if one is installed, from the rear of the blade enclosure.
- Step 2** Select the blade enclosure bay in which to install the switch module (Figure 2-1).



**Note** Figure 2-1 shows the IBM BC-H blade enclosure as an example. Your blade enclosure might look different.

**Figure 2-1** Blade Enclosure Rear-Panel View

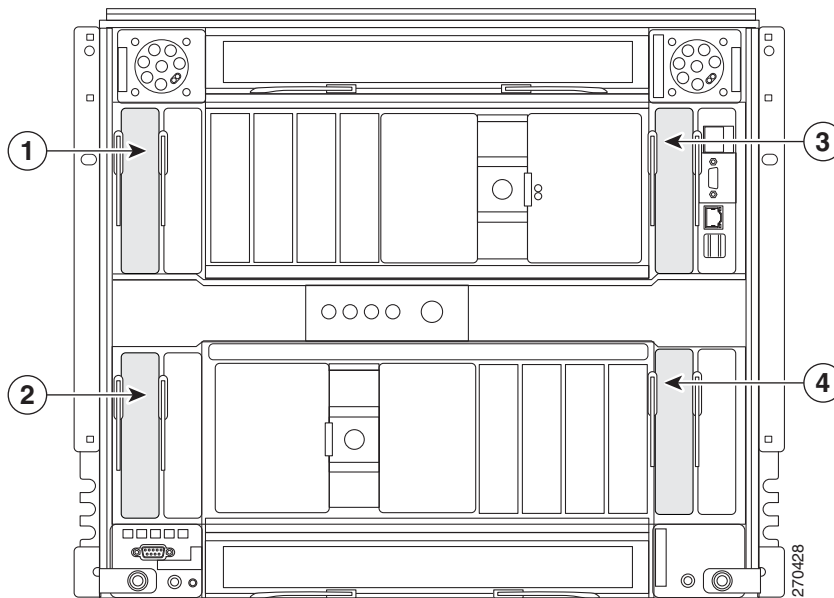

<b>1</b>	I/O module bay 1	<b>3</b>	I/O module bay 3
<b>2</b>	I/O module bay 2	<b>4</b>	I/O module bay 4

- Step 3** Remove the filler module from the selected bay. Store the filler module for future use.
- Step 4** If you have not already done so, touch the static-protective package that contains the switch module to any unpainted metal surface of the blade enclosure or any unpainted metal surface on any other grounded rack component for at least 2 seconds.
- Step 5** Remove the switch module from its static-protective package.
- Step 6** Move the switch module release latch to the open position (perpendicular to the switch module).

- Step 7** Slide the switch module into the bay until it stops (Figure 2-2).

**Figure 2-2** *Installing the Switch Module*

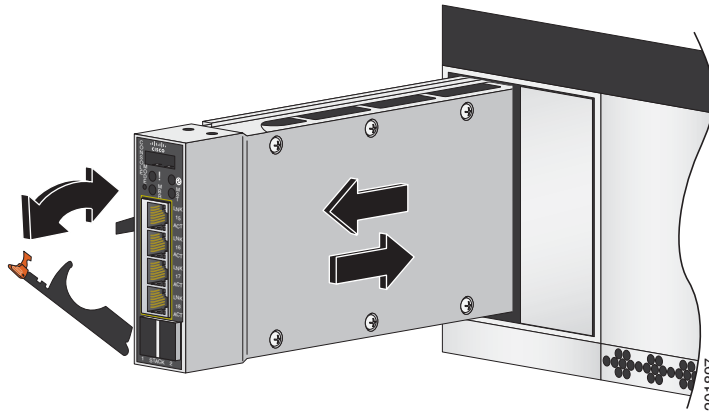

- Step 8** Move the switch module release latch to the closed position. After you insert and lock the switch module, it turns on, and the power-on self-test (POST) runs to verify that the switch module is operating correctly. The system power LED blinks green while POST is running and then turns solid green when POST is finished.
- Step 9** Confirm that the switch module system power LED is green. See the [“Switch Module LEDs”](#) section on page 1-5 for more information about the switch module LEDs.
- Step 10** Replace the acoustic-attenuation module, if applicable.

---

To remove the switch module, reverse the installation procedure. Place either another switch module or a filler module in the blade enclosure bay within 1 minute of removal.

## After Installing the Switch Module

After the switch module is installed, you might need to:

- Configure the switch module with the initial configuration. For instructions, see the switch module getting started guide on the documentation CD and also on Cisco.com.
- Connect the StackWise Plus cables to create a switch stack. See the [“Creating Switch Stacks”](#) section on page 2-6 for more information.
- Connect to the switch-module ports. See the [“Installing Devices in the 10-Gigabit Ethernet Slot”](#) section on page 2-11 and the [“Connecting Devices to the Ethernet Ports”](#) section on page 2-13.

# Creating Switch Stacks

This section is only for Catalyst Switch Module 3110G and 3110X and is optional.

A switch *stack* is a set of up to nine stacking-capable switch modules that are connected through their StackWise Plus ports. One switch module controls the operation of the stack and is called the stack master. The stack master and the other switch modules in the stack are stack members. Layer 2 and Layer 3 protocols present the entire switch stack as a single entity to the network. When switch modules are not stacked, each acts as a standalone switch module.

**Caution**

The Catalyst Switch Module 3110G and 3110X do not support switch stacks with other types of blades switches as members. Combining the switch module with other types of blade switches in a switch stack might cause the switch module to work improperly or to fail.

## Stacking Guidelines

Before you connect the switch modules in a stack, observe these stacking guidelines:

- You should install the stack master switch module and run the initial setup program on that switch module before you connect the StackWise Plus cables to other stack members. We recommend that you assign the highest priority value to the switch module that you prefer to be the stack master. This ensures that the switch module is re-elected as stack master if a re-election occurs. As you add new switch modules to the stack, they automatically become stack members.
- When you connect the StackWise Plus cables and create a stack, only the status of the stack master Fa0 interface appears in the switch module configuration, and it shows that the port is shut down while in stack mode.
- You can stack a combination of up to nine switch modules. You can stack only the Catalyst Switch Modules 3110G and 3110X; other blade switches are not supported.
- Although the StackWise Plus ports are numbered (1 and 2), you do not need to make specific port connections between switch modules.
- For conditions that might cause a stack master re-election and for general concepts and procedures to manage switch stacks, see the “Managing Switch Stacks” chapter in the switch module software configuration guide on Cisco.com.
- Before connecting, verify the StackWise Plus cable length. Depending on your configuration, you might need different sized cables. If you do not specify the length of the StackWise Plus cable when you order your product, the 1-meter cable is supplied. If you need the 0.5-meter cable or the 3-meter cable, you can order these StackWise Plus cables from your supplier:
  - CAB-STK-E-0.5M= (0.5-meter cable)
  - CAB-STK-E-1M= (1-meter cable)
  - CAB-STK-E-3M= (3-meter cable)

## Connecting a Switch Stack

Follow these steps:

- 
- Step 1** Install the member switch modules if you have not already done so.
  - Step 2** Remove the dust covers from the StackWise Plus cables, and store them for future use.
  - Step 3** Verify that cables are aligned as shown in [Figure 2-3](#). (The cables are keyed for correct insertion.)

**Figure 2-3** Connecting the StackWise Plus Cables

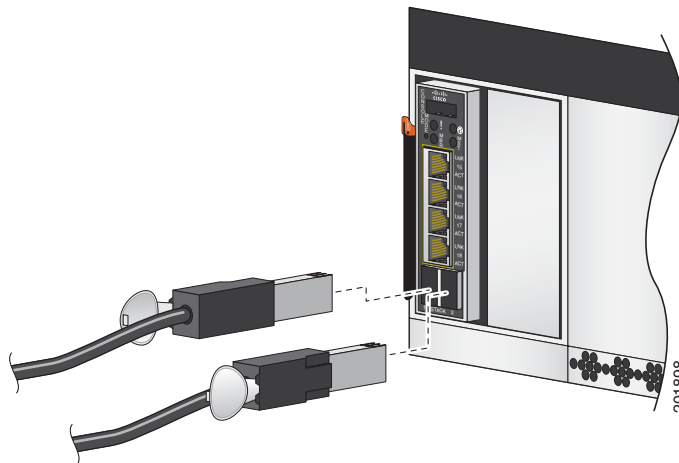

- Step 4** Insert the cable into the StackWise Plus port on the front panel of the switch module. Insert the other end of the cable into the connector of the other switch module.

Always use a Cisco-approved StackWise Plus cable to connect the switch modules.



**Caution** The new stack-member switch module restarts when you connect the StackWise Plus cables.

- Step 5** Configure the member switch modules through the master switch module by using the CLI through the console port of any stack member.

To remove the StackWise Plus cables, grasp the tab on the cable connector, and gently pull straight out. When you remove the StackWise Plus cables, replace the dust covers to protect them from dust.



**Caution**

Removing and installing the StackWise Plus cable can shorten its useful life. Do not remove and insert the cable more often than is absolutely necessary.

# Switch Stack Cabling Examples

Figure 2-4 is an example of a recommended configuration in which two switch modules create a switch stack in a single blade enclosure.

**Figure 2-4** Stacking Switch Modules in a Single Blade Enclosure to Create One Stack

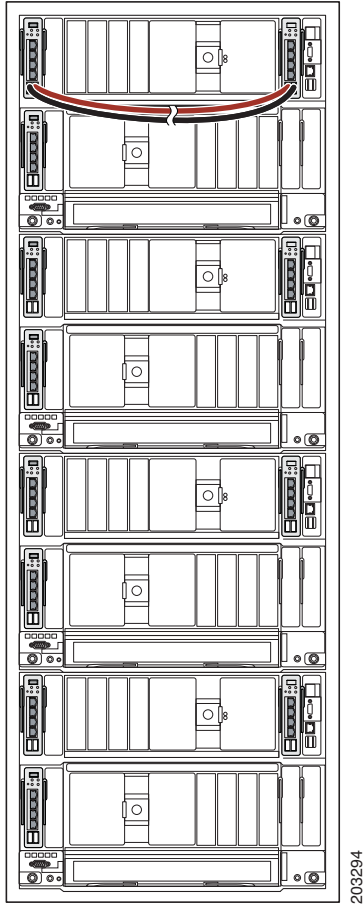



Figure 2-5 is an example of a recommended configuration in which eight switch modules create a switch stack in eight blade enclosures.

**Figure 2-5** Stacking Switch Modules in Blade Enclosures to Create One Stack

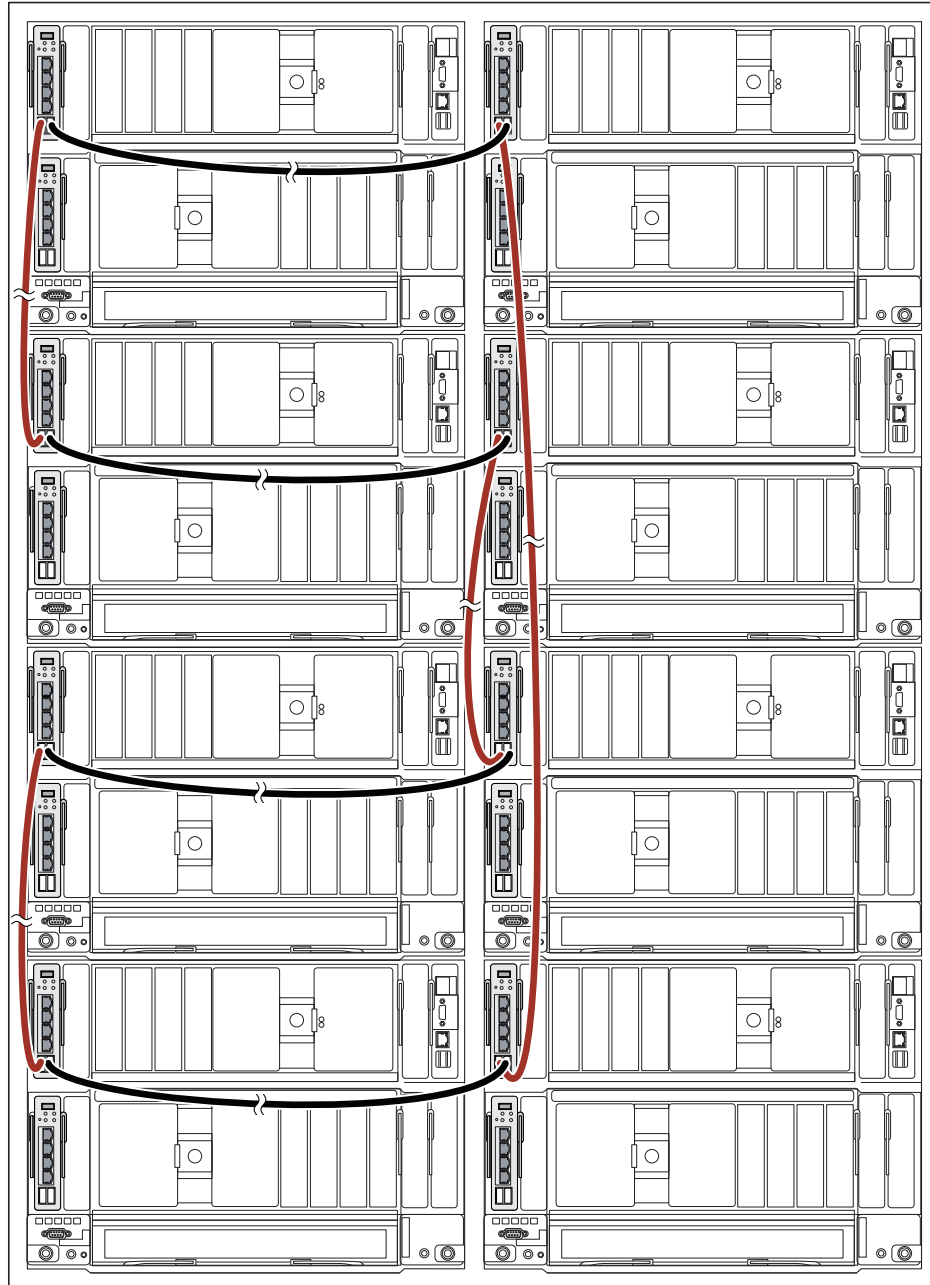
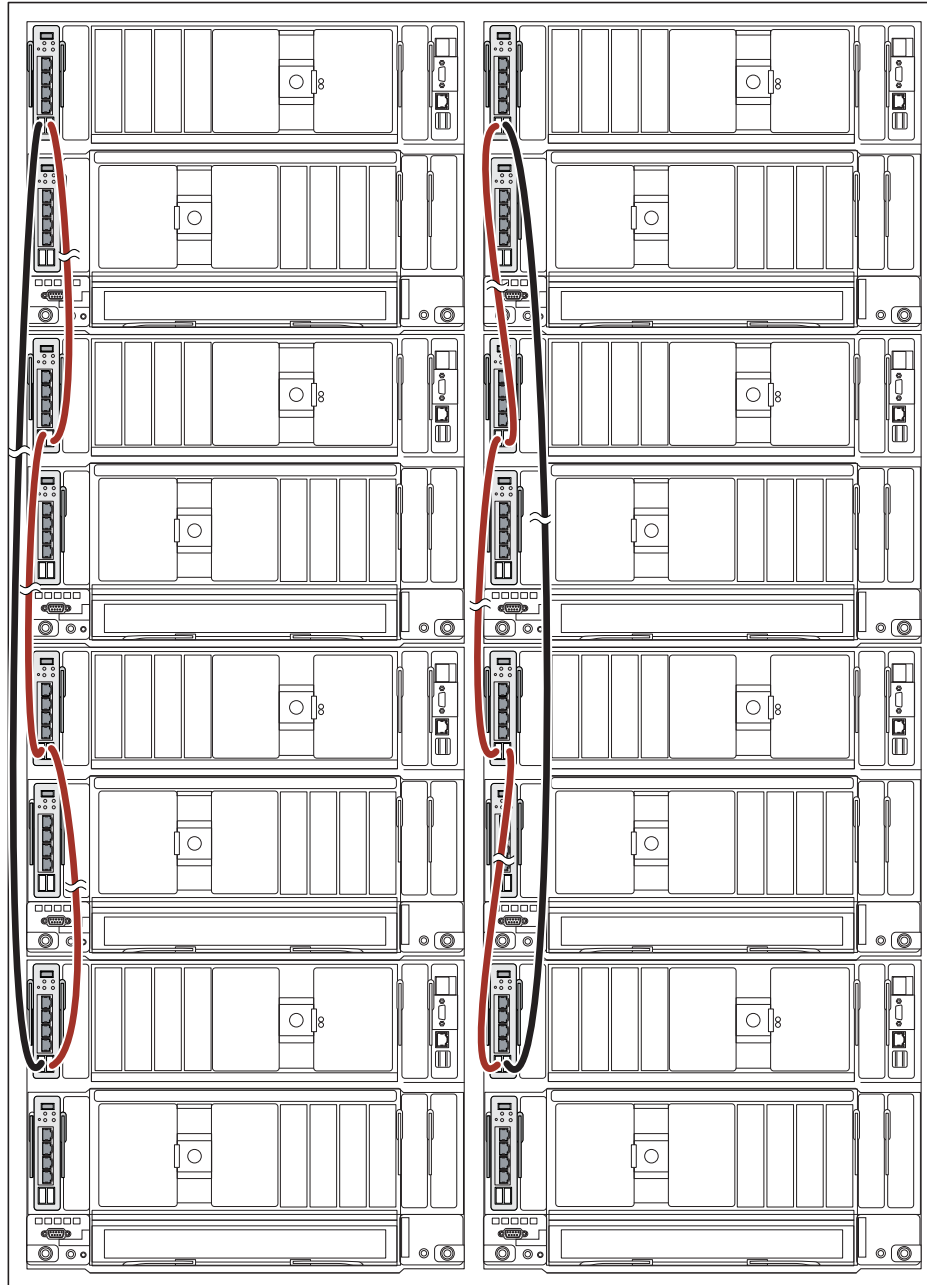

Figure 2-6 shows an example of a recommended configuration in which eight switch modules create two separate switch stacks in eight blade enclosures. This configuration provides redundant connections.

**Figure 2-6** Stacking Switch Modules in Blade Enclosures to Create Two Stacks



203296

# Installing Devices in the 10-Gigabit Ethernet Slot

This section describes how to install and remove X2 transceiver modules.

Use only Cisco X2 transceiver modules with the switch modules. Each Cisco module has an internal serial EEPROM that is encoded with security information. This encoding provides a way for Cisco to identify and validate that the module meets the requirements for the switch module.

For more information about installing, removing, cabling, and troubleshooting X2 transceiver modules, see the module documentation that shipped with your device. For module cable specifications, see [Appendix B, “Connector and Cable Specifications.”](#)

## Installing an X2 Transceiver Module

When installing an X2 transceiver module, observe these general precautions:

- Do not remove the module slot cover from the 10-Gigabit Ethernet slot until you are ready to install an X2 transceiver. Either a module or the module slot cover must be installed in the slot at all times.
- Do not remove the dust plugs from the fiber-optic X2 transceiver modules or the rubber caps from the fiber-optic cable until you are ready to connect the cable. The plugs and caps protect the module ports and cables from contamination and ambient light.
- Removing and installing an X2 module can shorten its useful life. Do not remove and insert any X2 module more often than is absolutely necessary.
- To prevent ESD damage, follow your normal board and component handling procedures when connecting cables to the switch module and other devices.

To install an X2 transceiver module, follow these steps:

- 
- Step 1** Attach an ESD-preventive wrist strap to your wrist and to a bare metal surface.
  - Step 2** Remove the module from the protective packaging.
  - Step 3** Remove the 10-Gigabit Ethernet module slot cover and save.
  - Step 4** Align the transceiver module in the module slot ([Figure 2-7](#)).

**Caution**

Verify the correct orientation of your module before inserting it into the slot. Incorrect insertion can damage the module.

- Step 5** Slide the transceiver module into the opening until the back of the module faceplate is flush with the switch module faceplate.

**Figure 2-7** Installing an X2 Transceiver Module

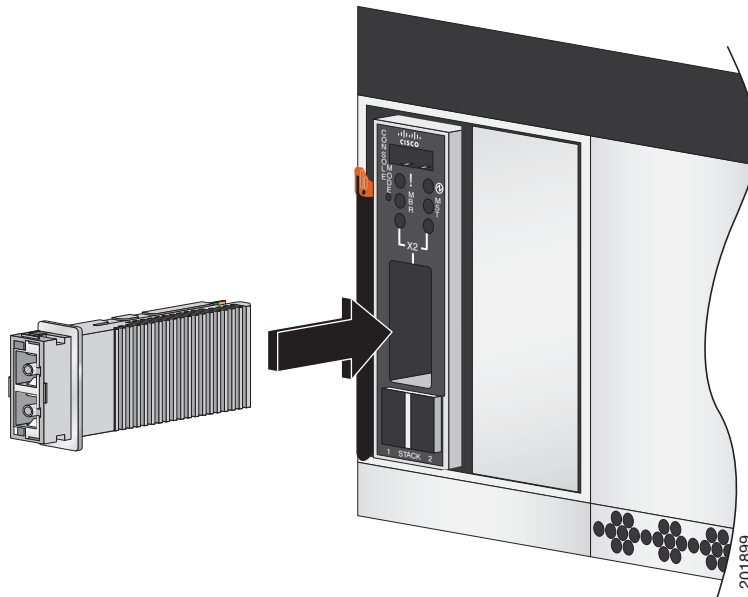

## Removing a Module

To remove an X2 transceiver module, follow these steps:

- Step 1** Attach an ESD-preventive wrist strap to your wrist and to a bare metal surface.
- Step 2** Disconnect the cables from the module. For fiber-optic modules, install the optical bore dust plugs.
- Step 3** Carefully pull on the X2 module sleeve to disengage it from the slot. Grasp the edges of the module, and carefully slide it out of the slot.
- Step 4** Reinstall a replacement module or the module slot cover in the 10-Gigabit Ethernet slot.
- Step 5** Place the module in an antistatic bag or other protective environment.

# Connecting Devices to the Ethernet Ports

The 10/100/1000 Ethernet ports use standard RJ-45 connectors with Ethernet pinouts. The maximum cable length is 328 feet (100 meters). The 100BASE-TX and 1000BASE-T traffic requires Category 5, Category 5e, or Category 6 UTP cable. The 10BASE-T traffic can use Category 3 or Category 4 cable.



## Caution

Category 5e and Category 6 cables can store high levels of static electricity. Always ground the cables to a suitable and safe earth ground before connecting them to the switch module or other devices.

The autonegotiation feature is enabled by default on the switch module. At this setting, the switch-module ports configure themselves to operate at the speed of attached device. If the attached device does not support autonegotiation, you can explicitly set the switch-module port speed and duplex parameters. To maximize performance, either let the ports autonegotiate both speed and duplex, or set the port speed and duplex parameters on both ends of the connection.

For simplified cabling, the automatic medium-dependent interface crossover (auto-MDIX) feature is enabled by default on the switch module. With auto-MDIX enabled, the switch module detects the required cable type for copper Ethernet connections and configures the interface accordingly. Therefore, you can use either a crossover or a straight-through cable for connections to a switch-module 10/100/1000 Ethernet port regardless of the type of device on the other end of the connection.

See the switch module software configuration guide and the command reference on Cisco.com for more information about enabling or disabling autonegotiation and auto-MDIX.

If auto-MDIX is disabled, use the guidelines in [Table 2-1](#) to select the correct cable for connecting the switch-module 10/100/1000 Ethernet ports to other devices. See the [“Cable and Adapter Specifications” section on page B-2](#) for cable-pinout descriptions.

**Table 2-1 Recommended Ethernet Cables (When Auto-MDIX is Disabled)**

Device	Crossover Cable <sup>1</sup>	Straight-Through Cable <sup>1</sup>
Switch module to switch module	Yes	No
Switch module to hub	Yes	No
Switch module to computer or server	No	Yes
Switch module to router	No	Yes
Switch module to IP phone	No	Yes

1. 100BASE-TX and 1000BASE-T traffic requires twisted four-pair, Category 5, Category 5e, or Category 6 cable. 10BASE-T traffic can use Category 3 or Category 4 cable.

## Where to Go Next

If the default configuration is satisfactory, the switch module does not need further configuration. You can use any of the management options described in the [“Management Options” section on page 1-9](#) to change the default configuration.





# CHAPTER 3

## Troubleshooting

---

This chapter describes these switch module troubleshooting topics:

- [Diagnosing Problems, page 3-1](#)
- [Resetting the Switch Module, page 3-4](#)
- [How to Replace a Failed Stack Member, page 3-5](#)

## Diagnosing Problems

The LEDs on the front panel provide troubleshooting information about the switch module. They show POST failures, port-connectivity problems, and fault indications. You can also get information from the device manager, from the CLI, or from an SNMP workstation. See the switch module software configuration guide and the command reference guide on Cisco.com or the documentation that came with your SNMP application for details.

## Verify Switch Module POST Results

As the switch module powers on, it begins the power-on self-test (POST), a series of tests that runs automatically to ensure that the switch module functions properly. It might take several minutes for the switch module to complete POST. When POST completes successfully, the System LED remains green. The other LEDs turn off and return to their operating status. If the switch module fails POST, the System LED is amber.



### Note

---

POST failures are usually fatal. Contact your Cisco technical support representative if your switch module does not pass POST.

---

## Verify Switch Module LEDs

If you have physical access to the switch module, look at the port LEDs for troubleshooting information about the switch module. See the [“Switch Module LEDs” section on page 1-5](#) for a description of the LED colors and their meanings.

## Verify Switch Module Connections

Review this section when troubleshooting switch module connection problems.

### Bad or Damaged Cable

Always evaluate the cable for marginal damage or failure. A cable might be just good enough to connect at the physical layer, but it could corrupt packets as a result of subtle damage to the wiring or connectors. You can identify this situation because the port has many packet errors or the port constantly flaps (loses and regains link). You should:

- Inspect or exchange the copper or fiber-optic cable with a known, good cable.
- Look for broken or missing pins on cable connectors.
- Rule out any bad patch panel connections or media convertors between the source and destination. If possible, bypass the patch panel or eliminate faulty media convertors (fiber-optic-to-copper).
- Try the cable in another port or interface, if possible, to see if the problem follows the cable.
- StackWise Plus cable: remove and inspect the cable and StackWise Plus port for bent pins or damaged connectors. If the StackWise Plus cable is bad, replace it with a known good cable.

### Ethernet and Fiber Cables

Make sure that you have the correct cable type for the connection:

- For Ethernet, use Category 3 copper cable for 10 Mb/s UTP connections. Use Category 5, Category 5e, or Category 6 UTP for 10/100 or 10/100/1000 Mb/s connections.
- For fiber-optic connectors, verify that you have the correct cable for the distance and port type. Make sure that the connected device ports both match and use the same type encoding, optical frequency, and fiber type. For more information about cabling, see the [“10-Gigabit Ethernet X2 Transceiver Module Cable Specifications” section on page B-3](#).
- For copper connections, determine if a crossover cable was used when a straight-through was required or the reverse. Enable auto-MDIX on the switch module, or replace the cable. See [Table 2-1](#) for recommended Ethernet cables.

### Link Status

Verify that both sides have link. A single broken wire or one shutdown port can cause one side to show link, but the other side does not have link.

A link LED does not guarantee that the cable is fully functional. The cable might have encountered physical stress that causes it to function at a marginal level. If the link light for the port does not come on:

- Connect the cable from the switch module to a known good device.
- Make sure that both ends of the cable are connected to the correct ports.
- Verify that both devices have power.
- Verify that you are using the correct cable type. See [Appendix B, “Connector and Cable Specifications”](#) for more information.
- Look for loose connections. Sometimes a cable appears to be seated, but is not. Disconnect the cable, and then reconnect it.



## Transceiver Issues

Use only Cisco X2 transceiver modules on the switch module. Each Cisco module has an internal serial EEPROM that is encoded with security information. This encoding provides a way for Cisco to identify and validate that the module meets the requirements for the switch module. Evaluate these items:

- Bad or wrong X2 transceiver module. Exchange suspect module with known good module. Verify that the module is supported on this platform. (The switch module release notes on Cisco.com list the X2 modules that the switch module supports.)
- Use the **show interfaces** privileged EXEC command to verify the port or module error-disabled, disabled, or shutdown status. Re-enable the port if needed.
- Make sure that all fiber connections are properly cleaned and securely connected.
- For CX4 module connections, make sure that cable routing does not violate the minimum allowed cable-bend radius. See the module documentation for specific cabling requirements.
- For LX4 modules, we recommend a mode conditioning patch for MMF applications.

## Port and Interface Settings

An obvious but sometimes overlooked cause of port connectivity failure is a disabled port. Verify that the port or interface is not disabled or powered down for some reason. If a port or interface is manually shut down on one side of the link or the other side, the link does not come up until you re-enable the port. Use the **show interfaces** privileged EXEC command to verify the port or interface error-disabled, disabled, or shutdown status on both sides of the connection. If needed, re-enable the port or the interface.

## Ping End Device

Test the end device by pinging from the directly connected switch module first, and then work your way back port by port, interface by interface, trunk by trunk, until you find the source of the connectivity issue. Make sure that each switch module can see the end device MAC address in its Content-Addressable Memory (CAM) table.

## Spanning Tree Loops

Spanning Tree Protocol (STP) loops can cause serious performance issues that look like port or interface problems. In this situation, the switch module bandwidth is used over and over again by the same frames, leaving little room for legitimate traffic.

Loops can be caused by a unidirectional link. A unidirectional link occurs whenever the traffic sent by the switch module is received by its neighbor, but the traffic from the neighbor is not received by the switch module. A broken fiber-optic cable, other cabling, or a port issue could cause this one-way communication.

You can enable UniDirectional Link Detection (UDLD) on the switch module to help identify difficult-to-find unidirectional link problems. UDLD supports two modes of operation: normal (the default) and aggressive. In normal mode, UDLD detects unidirectional links due to misconnected interfaces on fiber-optic connections. In aggressive mode, UDLD also detects unidirectional links due to one-way traffic on fiber-optic and twisted-pair links and due to misconnected interfaces on fiber-optic links. For information about enabling UDLD on the switch module, see the “Understanding UDLD” section in the software configuration guide for this release.

## Verify Switch Module Performance

Review this section when troubleshooting switch module performance problems.

### Speed, Duplex, and Autonegotiation

If the port statistics show a large amount of alignment errors, frame check sequence (FCS), or late-collisions errors, this might mean a speed or duplex mismatch.

A common issue with speed and duplex is when the duplex settings are mismatched between two switch modules, between a switch module and a router, or between the switch module and a workstation or server. This can happen when manually setting the speed and duplex or from autonegotiation issues between the two devices. A mismatch occurs under these circumstances:

- A manually set speed or duplex parameter is different from the manually set speed or duplex parameter on the connected port.
- A port is set to autonegotiate, and the connected port is set to full duplex with no autonegotiation.

To maximize switch module performance and ensure a link, follow one of these guidelines when changing the settings for duplex and speed:

- Let both ports autonegotiate both speed and duplex.
- Manually set the speed and duplex parameters for the ports on both ends of the connection.
- If a remote device does not autonegotiate, configure the duplex settings on the two ports to match. The speed parameter can adjust itself even if the connected port does not autonegotiate.

### Autonegotiation and Network Interface Cards

Problems sometimes occur between the switch module and third-party network interface cards (NICs). By default, the switch module ports and interfaces are set to autonegotiate. It is common for devices like laptops or other devices to be set to autonegotiate as well, yet sometimes autonegotiation issues occur.

To troubleshoot autonegotiation problems, try manually setting both sides of the connection. If this does not solve the problem, there could be a problem with the firmware or software on your NIC. You can resolve this by upgrading the NIC driver to the latest version available from the manufacture.

### Cabling Distance

If the port statistics show excessive FCS, late-collision, or alignment errors, verify that the cable distance from the switch module to the connected device meets the recommended guidelines. See the [“Cable and Adapter Specifications”](#) section on page B-2 for cabling guidelines.

## Resetting the Switch Module

For a standalone switch, you can perform these functions by using the AMM web interface:

- Reboot the switch
- Restore factory defaults
- Set or reset the IP address, netmask, and default gateway
- Enable or disable external ports

- Enable or disable management through the external ports
- Change configuration
- Change or update firmware

For a switch stack, you can use the CLI to perform the same functions. For more information, see the switch module software configuration guide and the command reference on Cisco.com.

## Using the Mode Button to Reset the Switch Module

You can use the Mode button to reset a standalone switch module.



### Caution

For a standalone switch module, resetting the switch module deletes the configuration and reboots the switch module.

For a standalone switch module, use a small pointed object to press and hold the Mode button on the switch module front panel. The switch module LEDs begin blinking after about 3 seconds. Continue holding down the Mode button. The LEDs stop blinking after 7 more seconds, and then the switch module reboots.

The switch module is now unconfigured. You can enter the switch module IP information by following the procedures described in the switch module getting started guide on Cisco.com,

For switch stacks, pressing and holding the Mode button on a member switch module causes the stack to reboot. It does not remove the configuration from any member switch.

## How to Replace a Failed Stack Member

If you need to replace a failed stack member, you can hot swap or replace the switch module by following this procedure (only Catalyst 3110 switch modules):

1. Get a replacement switch module that has the same model number as the failed switch module.
2. Disconnect and remove any modules and cable connections.
3. Remove the failed switch module.
4. Install and then connect the replacement switch module to the stack.

If you had manually set the member numbers for any members in the stack, you need to manually assign the replacement switch module with the same member number as the failed switch module. To manually assign the member number, see the switch module software configuration guide on Cisco.com.

5. Make the same Gigabit Ethernet connections on the replacement switch module that were on the failed switch module.
6. Reinstall any modules and cable connections.

The replacement switch module will have the same configuration for all the interfaces as the failed switch module and will function the same as the failed switch module.





# APPENDIX **A**

## Technical Specifications

This appendix lists the Catalyst Switch Module 3110G, 3110X, and 3012 technical specifications in [Table A-1](#) and [Table A-2](#).

**Table A-1**      *Switch Module Environmental and Physical Specifications*

<b>Environmental Ranges</b>	
Operating temperature	32 to 131°F (0 to 55°C)
Storage temperature	-13 to 158°F (-25 to 70°C)
Relative humidity	10 to 85% (noncondensing)
Operating altitude	Up to 10,000 ft (3049 m)
Storage altitude	Up to 15,000 ft (4573 m)
<b>Physical Specifications</b>	
Weight	2.1 lb (0.95 kg)
<b>Physical Specifications</b>	
Dimensions (H x D x W)	1.22 x 4.65 x 10.79 in. (3.1 x 11.8 x 27.4 cm)

**Table A-2**      *Power Specifications*

<b>Power Specifications</b>	
Maximum power	45 W
Input voltage range and frequency	12 VDC +/- 10%
Input current maximum	3.3 A
Total input BTU	135 Btus per hour, 39.6 W





# APPENDIX **B**

## Connector and Cable Specifications

This appendix describes the cables and adapters that you use to connect the Catalyst Switch Module 3110G, 3110X, and 3012 to other devices. This appendix includes these sections:

- “Connector Specifications” section on page B-1
- “Cable and Adapter Specifications” section on page B-2

### Connector Specifications

These sections describe the connectors used with the switch modules:

- 10/100/1000 Ports, page B-1
- 10-Gigabit Ethernet Module Interface, page B-2
- Console Port, page B-2

### 10/100/1000 Ports

The 10/100/1000 Ethernet ports on switch modules use standard RJ-45 connectors and Ethernet pinouts. [Figure B-1](#) shows the pinouts.

**Figure B-1** 10/100/1000 Port Pinouts

Pin	Label	1 2 3 4 5 6 7 8
1	TP0+	
2	TP0-	
3	TP1+	
4	TP2+	
5	TP2-	
6	TP1-	
7	TP3+	
8	TP3-	

## 10-Gigabit Ethernet Module Interface

The 10-Gigabit Ethernet optical modules use SC connectors or Infiniband 4x connectors, as shown in [Figure B-2](#) and [Figure B-3](#).

**Figure B-2** 10-Gigabit Ethernet Optical Module SC Connector

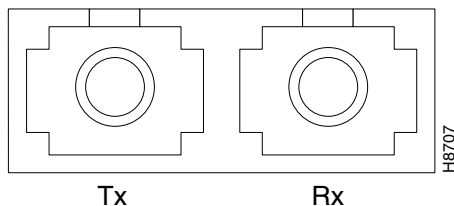

**Figure B-3** 10-Gigabit Ethernet Infiniband 4x Connector

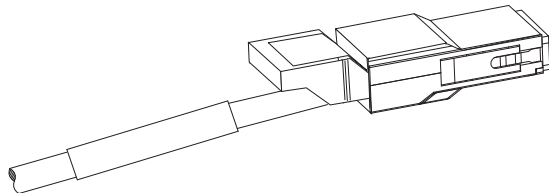

## Console Port

The console port uses a USB connector. The supplied USB-to-DB-9 adapter cable is used to connect the console port of the switch module to a PC.

## Cable and Adapter Specifications

These sections describe the cables and adapters used with the switch module:

- [10-Gigabit Ethernet X2 Transceiver Module Cable Specifications, page B-3](#)
- [Four Twisted-Pair Cable Pinouts, page B-4](#)
- [Two Twisted-Pair Cable Pinouts, page B-5](#)
- [Identifying a Crossover Cable, page B-5](#)



## 10-Gigabit Ethernet X2 Transceiver Module Cable Specifications

Table B-1 lists the port cabling specifications for the 10-Gigabit Ethernet X2 transceiver modules. Each port must match the wave-length specifications on the other end of the cable, and for reliable communications, the cable must not exceed the stipulated cable length. Table B-2 lists the transceiver optical transmit and receive specifications.

**Table B-1 X2 Transceiver Port Cabling Specifications**

X2 Product Number	Wavelength (nm)	Cable Type	Core Size (microns)	Modal Bandwidth (MHz/km)	Maximum Cabling Distance
X2-10GB-SR	850	MMF	62.5	160	85 feet (26 m)
			62.5	200	108 feet (33 m)
			50.0	400	217 feet (66 m)
			50.0	500	269 feet (82 m)
			50.0	2000	984 feet (300 m)
X2-10GB-LX4	1310	MMF <sup>1</sup>	62.5	500	984 feet (300 m)
			50.0	400	787 feet (240 m)
			50.0	500	984 feet (300 m)
X2-10GB-CX4	—	InfiniBand (copper)	—	—	49 feet (15 m)

1. Mode conditioning patch cord is recommended for MMF applications.

**Table B-2 X2 Transceiver Optical Transmit and Receive Specifications**

X2 Product Number	Transceiver Type	Transmit Power (dBm)	Receive Power (dBm)	Transmit and Receive Wavelength (nm)
X2-10GB-SR	10GBASE-SR, 850-nm MMF	-1 <sup>1</sup> (Max) -7.3 (Min)	-1.0 (Max) -9.9 (Min)	840 to 860
X2-10GB-LX4	10GBASE-LX4 WWDM 1300-nm MMF	-0.5 per lane (Max) —	-0.5 (Max) -14.4 per lane	Four lanes; overall range: 1269 to 1356

1. The launch power shall be the lesser of the Class 1 safety limit or the maximum receive power. Class 1 laser requirements are defined by IEC 60825-1: 2001.

## Four Twisted-Pair Cable Pinouts

Figure B-4 and Figure B-5 show the schematics of four twisted-pair cables.

**Figure B-4** *Four Twisted-Pair Straight-Through Cable Schematic*

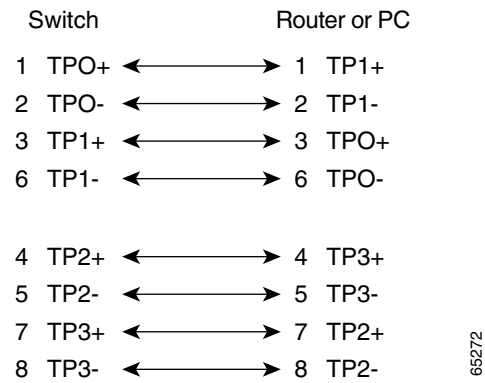
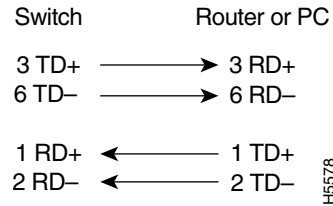

**Figure B-5** *Four Twisted-Pair Crossover Cable Schematic*

## Two Twisted-Pair Cable Pinouts

Figure B-6 and Figure B-7 show the schematics of two twisted-pair cables.

**Figure B-6** Two Twisted-Pair Straight-Through Cable Schematic



**Figure B-7** Two Twisted-Pair Crossover Cable Schematic

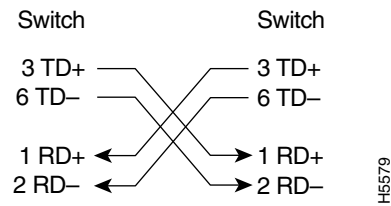

## Identifying a Crossover Cable

To identify a crossover cable, compare the two modular ends of the cable. Hold the cable ends side-by-side, with the tab at the back. The wire connected to the pin on the outside of the left plug should be the same color as the wire connected to the pin on the outside of the right plug. (See Figure B-8.)

**Figure B-8** Identifying a Crossover Cable

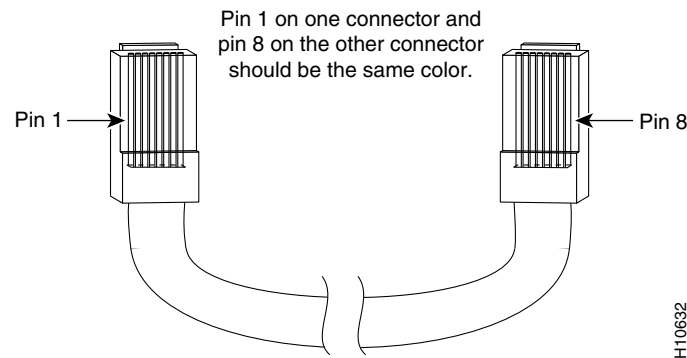





## INDEX

---

### Numerics

- 10/100/1000 ports
  - cable lengths [1-3, 2-13](#)
  - connecting to [2-13](#)
  - described [1-3](#)
  - pinouts [B-1](#)
  - recommended cables [2-13](#)
- 10-Gigabit Ethernet module slots described [1-4](#)

---

### A

- AC power specifications [A-1](#)
- altitude, operating and storage [A-1](#)
- autonegotiation
  - default setting [2-13](#)
  - troubleshooting [3-4](#)

---

### B

- BladeCenter Advanced Management Module described [1-9](#)

---

### C

- cable lengths [B-2](#)
- cables
  - crossover
    - four twisted-pair pinout [B-4](#)
    - identifying [B-5](#)
    - two twisted-pair pinout [B-5](#)
  - recommended [2-13](#)
  - StackWise Plus part numbers [1-9](#)

straight-through

- four twisted-pair pinout [B-4](#)
- two twisted-pair pinout [B-5](#)
- X2 transceiver module [B-3](#)
- Cisco IOS command-line interface [1-9](#)
- Cisco IP Phones, connecting to [2-13](#)
- Cisco Network Assistant [1-10](#)
- CiscoView [1-10](#)
- Class 1 laser warning [2-2](#)
- CLI [1-9](#)
- code compliance warning [2-2](#)
- command-line interface
  - See CLI
- connectors and cables [B-1 to B-5](#)
- console port
  - connectors and cables [B-2](#)
  - described [1-9](#)
- crossover cable
  - See cables

---

### D

- device manager described [1-10](#)
- diagnosing problems [3-1](#)
- dimensions [A-1](#)
- duplex
  - default setting [2-13](#)
  - troubleshooting [3-4](#)

---

### E

- electrical noise, avoiding [2-3](#)
- Ethernet and fiber cable troubleshooting [3-2](#)

**F**

## front panel

- 10/100/1000 Ethernet ports [1-3](#)
- 10-Gigabit Ethernet module slots [1-4](#)
- clearance [2-3](#)
- console port [1-9](#)
- LEDs [1-5 to 1-9](#)
- StackWise Plus ports [1-9](#)

**H**

humidity, relative [A-1](#)

**I**

IBM Director described [1-10](#)

## installation

- installing the switch module [2-4](#)
- site requirements [2-3](#)

installing X2 transceiver modules [2-11](#)

**J**

jewelry removal warning [2-1](#)

**L**

## LEDs

- fault [1-7](#)
- fault/stack mode [1-7](#)
- front panel [1-5 to 1-9](#)
- master [1-6](#)
- port [1-8](#)
- POST results [3-1](#)
- stack member [1-7](#)
- system power [1-6](#)
- troubleshooting with [3-1](#)

lightning activity warning [2-2](#)

link status troubleshooting [3-2](#)

local and national electrical codes compliance [2-2](#)

**M**

mode button [1-5](#)

**N**

noise, electrical [2-3](#)

**O**

outside connections warning [2-2](#)

**P**

## pinouts

- 10/100/1000 ports [B-1](#)
- adapters [B-5](#)
- crossover cables
  - four twisted-pair [B-4](#)
  - two twisted-pair [B-5](#)
- straight-through cables
  - four twisted-pair [B-4](#)
  - two twisted-pair [B-5](#)

port and interface troubleshooting [3-3](#)

port LEDs [1-8](#)

## port modes

- changing [1-5](#)
- See also mode button

## ports

- 10/100/1000
  - connecting to [2-13](#)
  - described [1-3](#)
  - pinouts [B-1](#)
  - recommended cables [2-13](#)

**POST**

- LEDs [3-1](#)
- running at power on [3-1](#)
- power connection warning [2-2](#)
- power specifications [A-1](#)
- product disposal warning [2-2](#)

---

**S**

- safety [2-1](#)
- Simple Network Management Protocol
  - See SNMP
- SNMP network management platforms [1-10](#)
- software switch management [1-9](#)
- specifications [A-1](#)
- speed
  - default setting [2-13](#)
  - troubleshooting [3-4](#)
- StackWise Plus ports [1-9](#)
- straight-through cable pinout
  - four twisted-pair [B-4](#)
  - two twisted-pair [B-5](#)
- switch modules described [1-1](#), [1-2](#)
- system power LED [1-6](#)

---

**T**

- technical specifications [A-1](#)
- Telnet, and accessing the CLI [1-9](#)
- temperature, operating [A-1](#)
- troubleshooting
  - bad or damaged cable [3-2](#)
  - connection problems [3-2](#)
  - diagnosing problems [3-1](#)
  - Ethernet and fiber cables [3-2](#)
  - link status [3-2](#)
  - ping end device [3-3](#)
  - port and interface settings [3-3](#)

**POST** [3-1](#)

- spanning tree loops [3-3](#)
- speed, duplex, and autonegotiation [3-4](#)
- switch performance [3-4](#)
- transceivers [3-3](#)
- with LEDs [3-1](#)

---

**U**

- USB connector, console port [1-9](#), [B-2](#)

---

**W**

- warnings
  - Class 1 laser [2-2](#)
  - code compliance [2-2](#)
  - connecting outside of building [2-2](#)
  - connecting the power [2-2](#)
  - disposal of product [2-2](#)
  - installation [2-1](#)
  - lightning activity [2-2](#)
  - removing jewelry [2-1](#)
- weight [A-1](#)

---

**X**

- X2 transceiver modules
  - described [1-4](#)
  - installing [2-11](#)
  - removing [2-12](#)

